

CC-998

Installation Instructions

Heavy-duty Easy Connect Catch 'N' Close System

- Prevents bouncing and slamming of sliding doors
- Can be installed on both opening and closing ends of doors as narrow as 20 in [508 mm]
- Cycle tested up to 150,000 times
- For up to 300 lbs. [136 kg] using CC-998 with CC-3

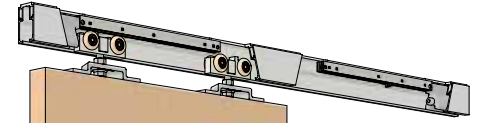

Parts List

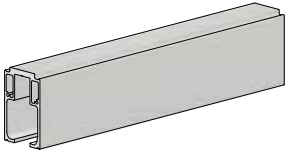

CC-904 Top Mount Track x length (1)

Length = 2 x door width, example:

36 in [914 mm] door = 72 in [1829 mm] track

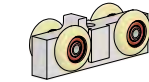

CC-912 Hanger Body (2)

c/w wheels



1/2-13 x 2-1/4" Hex Flange Bolt (2)

[FT34]

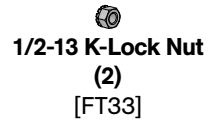

1/2-13 K-Lock Nut (2)

[FT33]

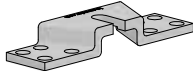

C-998 Top Plate (2)



#12 x 2-1/4" Flathead Screws (16)

[FT52]



#10 x 1-1/4" Pan Head Screws (8)

[FT4]



CC-2 Catch 'N' Close Closing Device (2)

See details in instruction steps



#10 x 1-1/2" Self-Drilling Screws (4)

[FT5]

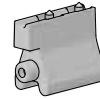

CC-101HD Catch 'N' Close In-Track Stops (2)

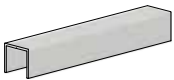

C-914 Guide Channel x length (1)

Length = door width, example:

36 in [914 mm] door = 36 in [914 mm] guide channel less set-backs if desired



#8 x 3/4" Pan Head Screws (4)

[FT2]

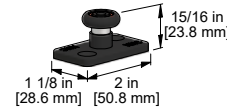

C-913 Floor Guide (1)



#10 x 1-1/2" Flathead Screws (2)

[FT7]

Complete CC-998 kit illustrated. Cut-outs in track to expose components.

Optional Add-on Products

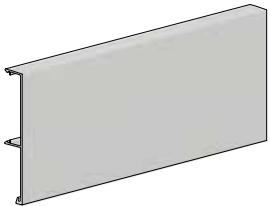

CC-940 Snap-on Fascia x length

Length = same as track length, example:

72 in [1829 mm] track = 72 in [1829 mm] fascia

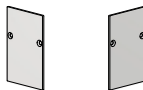

CC-941 End Caps (2)

Left and right

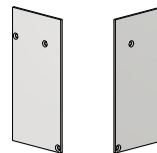

CC-942 End Caps (2)

Left and right

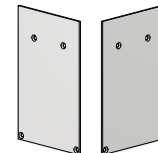

CC-943 End Caps (2)

Left and right



#4 x 5/16" Flathead Screws for end caps (2)

[FT29]

Production Details and Dimensions

Elevation View

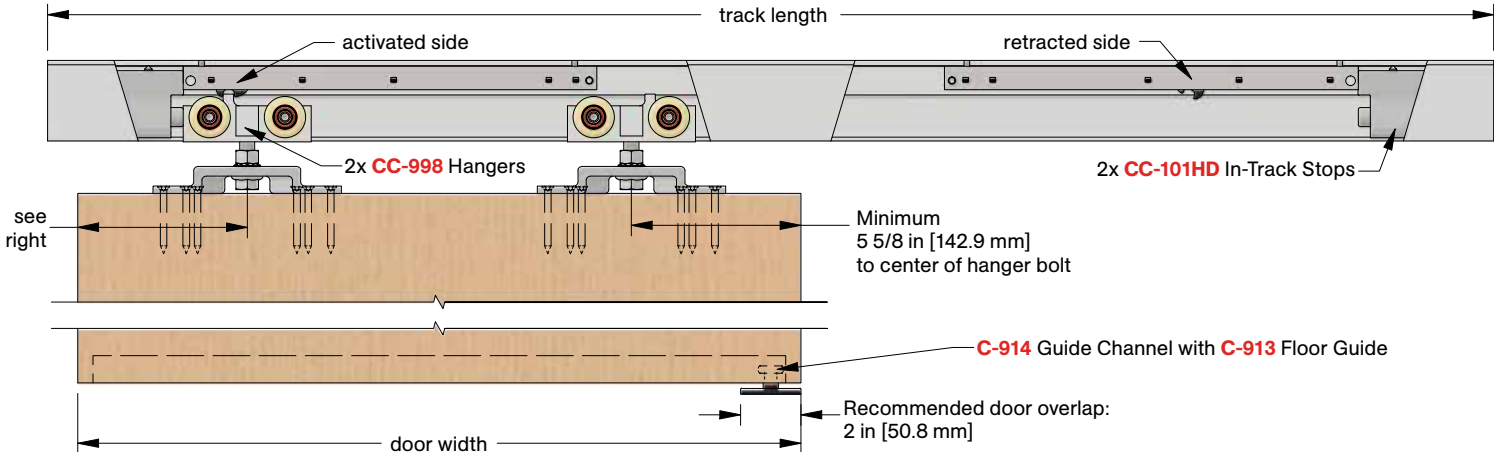

Section View

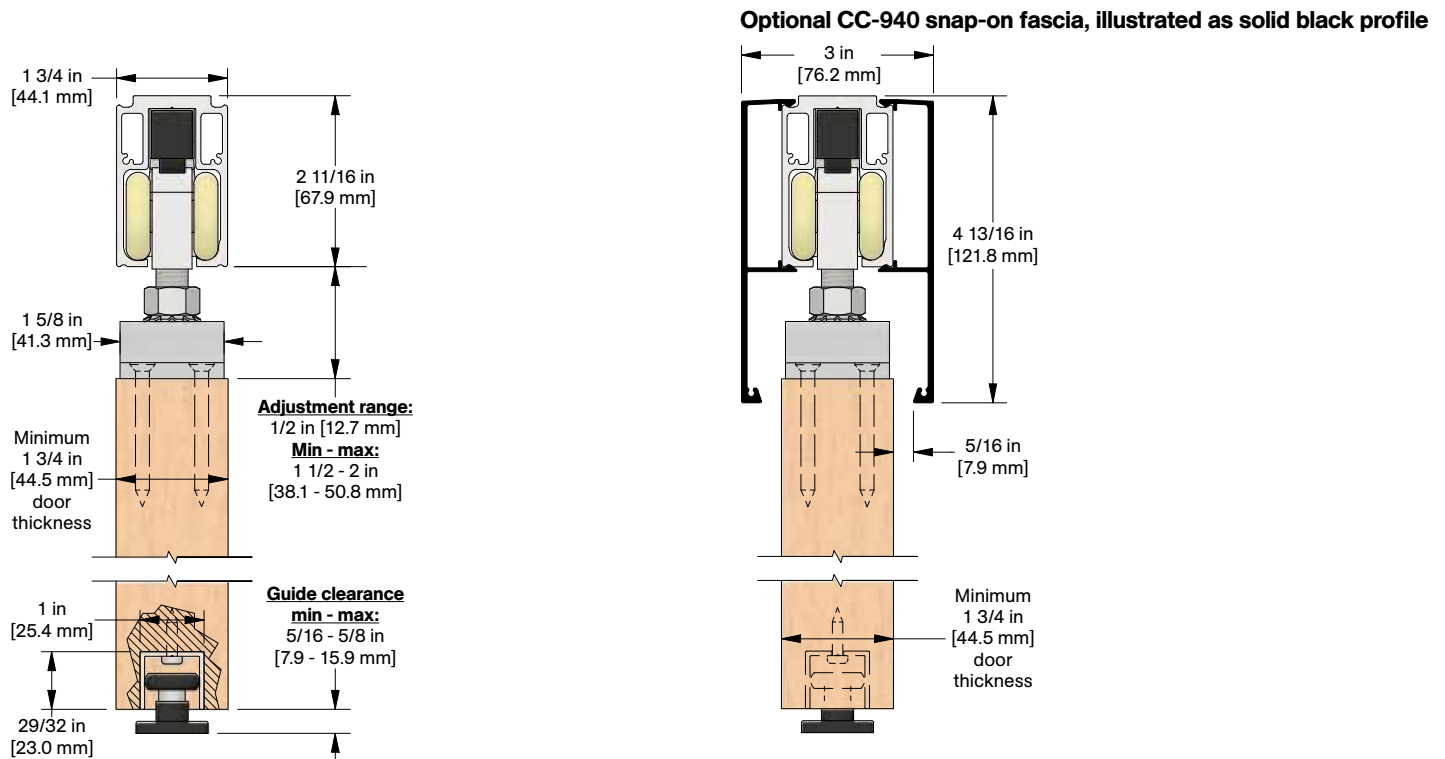

Typical installation location for floor guides

For pocket door applications

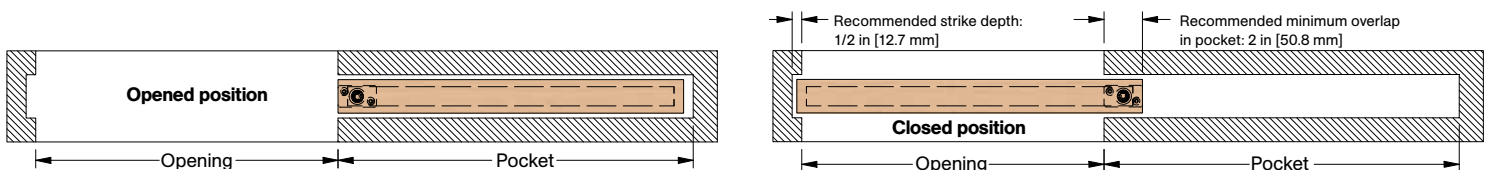

Installation Steps

Step #1:

Determine door size, header height, track position, and bottom clearance based on kit code ordered by using dimensions shown in detail views on previous page.

Step #2:

Note: If access to ends of track is not available, steps #3 and 4 must be completed before step #2.

Cut CC-904 aluminum track to size if required, typically 2 x door width. Locate and pre-drill holes through center of track. Secure track to structural support/backing.

Note: Starting hole locations at each end of track should be 1/2 in [12.7 mm] from end and then 19 in [482.6 mm] from first hole. Minimum #10 screws or 1/4 in [6.3 mm] structural bolts recommended to secure track. Solid backing is required. Spacing is recommended to be between 12-16 in [304-406 mm] on center. Consult structural engineer to ensure adequate support and fastening.

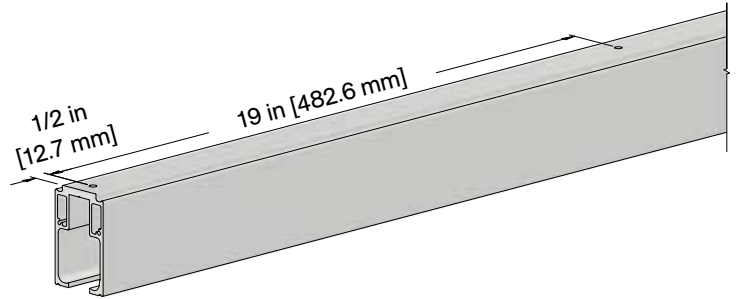

Step #3:

Assemble CC-998 Catch 'N' Close Hangers as shown right:

Fig. 1 Thread 1/2-13 K-Lock nut [FT33] onto 1/2-13 Hex Head Flange Bolt [FT34] with lock washer facing bolt head.

Fig. 2 Thread assembly from **Fig. 1** into CC-912 Hanger Body from underside, side opposite the trigger, do not thread in fully.

Fig. 3 Completed CC-998 Hanger assembly, 2 x required.

Fig. 1

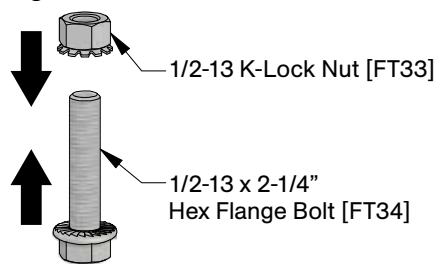

Fig. 2

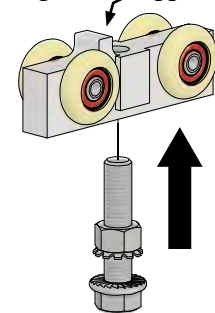
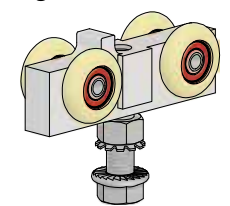

Fig. 3



Step #4:

Slide one (1) CC-998 Hanger assembly (★) with trigger facing end of track and one (1) CC-101HD In-Track Stop (●) into each end of track, as shown below.

Note: Leave screws on CC-101HD In-Track Stops (●) loose to allow stops to slide freely within track. Rubber bumpers of each stop (●) should face inward, toward middle of track.

★ CC-998 Hanger

● CC-101HD In-Track Stops

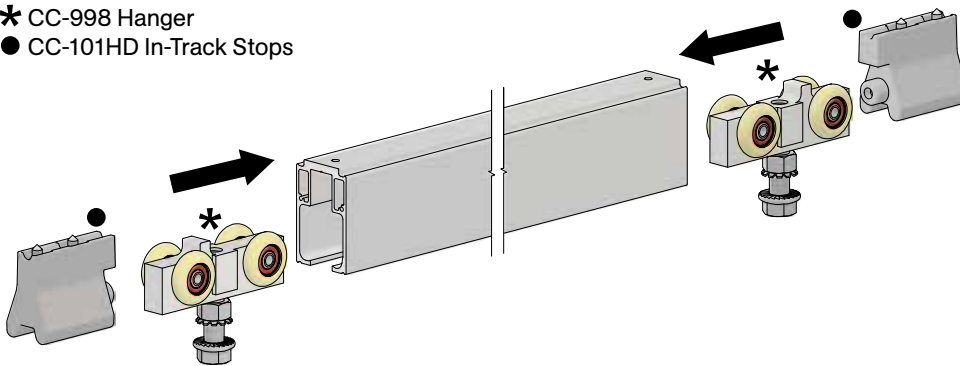
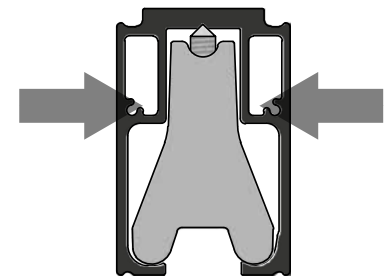
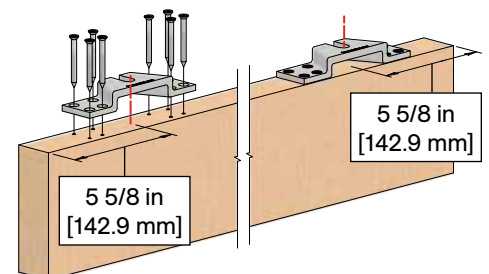

Illustration below shows correct positioning of stops in track



Step #5:

Locate center of "U" slot, dash line shown right, of C-998 Top Plate at 5 5/8 in [142.9 mm] from each edge of door or 2 1/2 in [63.5 mm] from edge of door to leading edge of top plate. Mark screw hole locations or use template on page 8 and pre-drill Ø9/64 in [3.6 mm] holes at least 2 1/4 in [57.2 mm] deep. Secure C-998 Top Plates with (8 per hanger) #12 x 2-1/4" Flathead Screws [FT52]. See right.



Note: If door has sufficient overlap, guide channel can be recessed into door without cutting a full-length slot in door. If guide channel will be fully recessed, it is recommended to have at least 1/2 in [12.7 mm] door material at each end of door before start of guide channel slot.

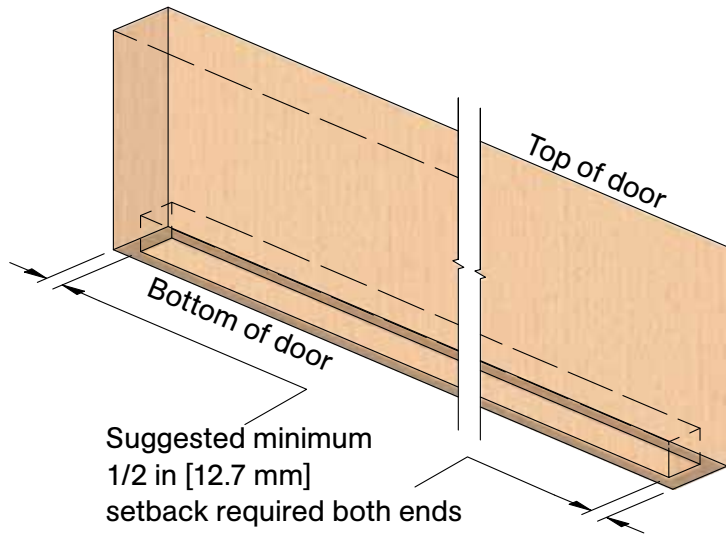

Step #6:

Prepare C-914 Guide Channel slot in bottom of door: 1 in [25.4 mm] wide in center of door, 29/32 in [23 mm] deep and set back 1/2 in [12.7 mm] from both edges of door. Make slot as accurate as possible for secure fit and neat appearance.

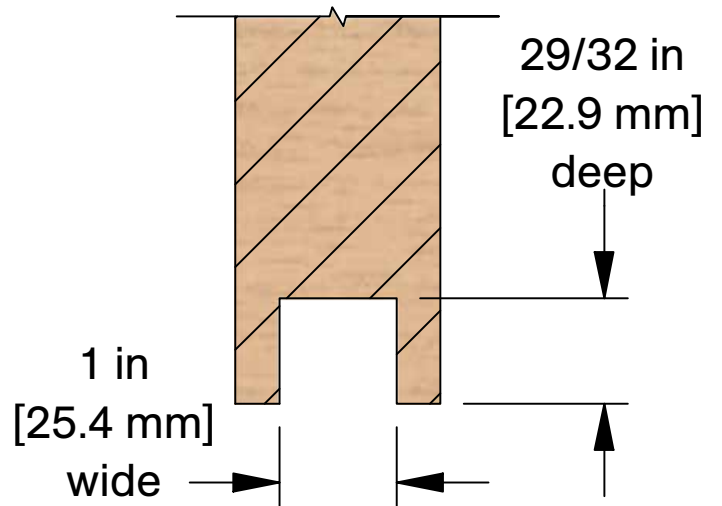

Step #7:

Cut C-914 aluminum guide channel to correct length as required. Drill holes in C-914 Guide Channel and pre-drill holes in door. Locate C-914 Guide Channel in slot and secure channel in place with (4) #8 x 3/4" Pan Head Screws [FT2].

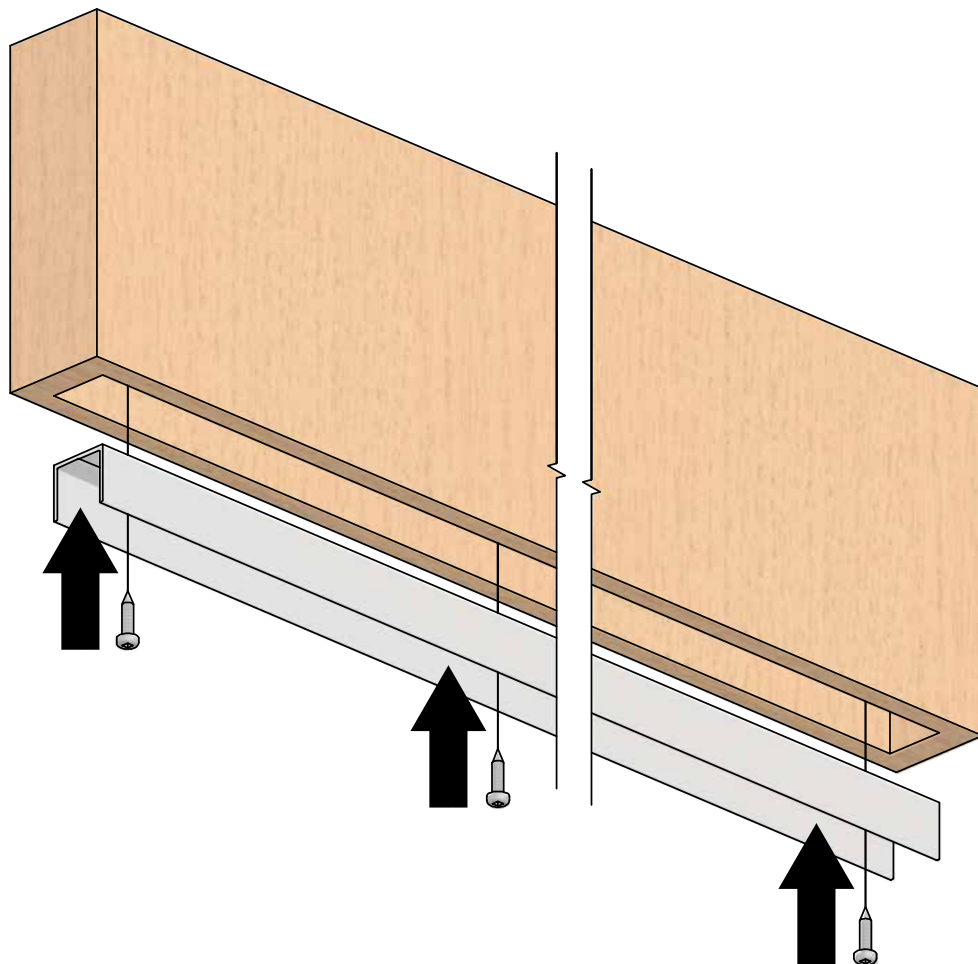

Step #8:

Position C-913 Guide per typical installation location details, page 2, and secure to floor with (2) #10 x 1-1/2" Flathead Screws [FT7].

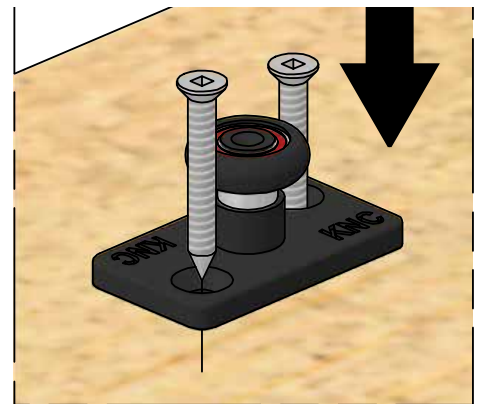

For 120 in [3048 mm] kits and up, C-913-2 Double Roller Floor Guide is supplied. Minimum 4 in [101.6 mm] overlap required.

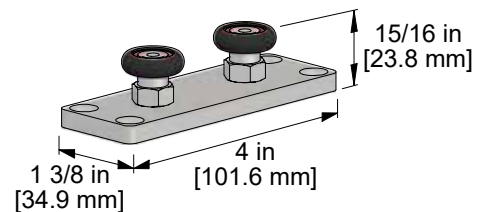

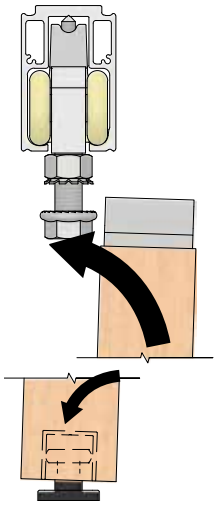

Step #9:

Raise door, position over guide, and under hangers in track. Lift door up and engage top plate "U" slot with 1/2-13 Hex Head Flange Bolt. Adjust door height and plumb by using 3/4 in [19 mm] wrench on hex head flange bolts. Lock final height adjustment with k-lock nuts using 3/4 in [19 mm] wrench.

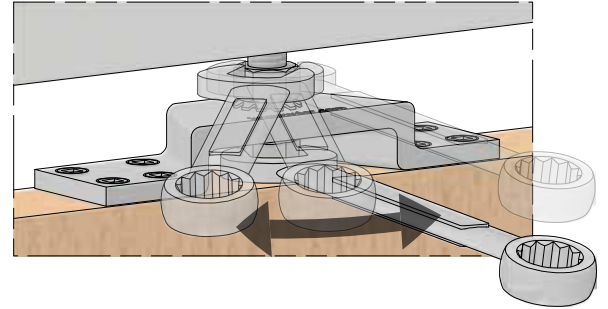
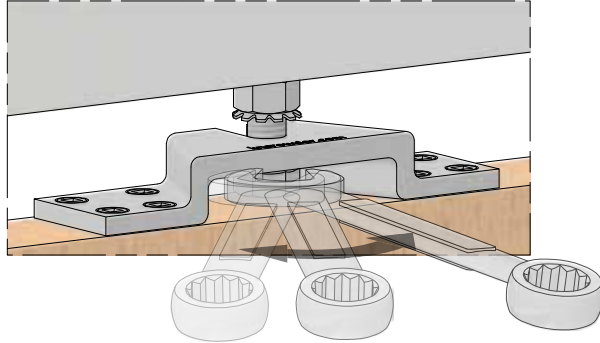

Step #10:

After door has been installed, position door approximately 5-10 in [127-254 mm] away from final position at one end, shown below with left side. Push loose CC-101HD Stop, installed in **step #4**, against hanger body as shown below.



Step #11:

With CC-101HD Stop loose, slide door to final/desired position of door as shown below.

Note: Ensure that strike and trim thickness are taken into consideration for final/desired position of door.

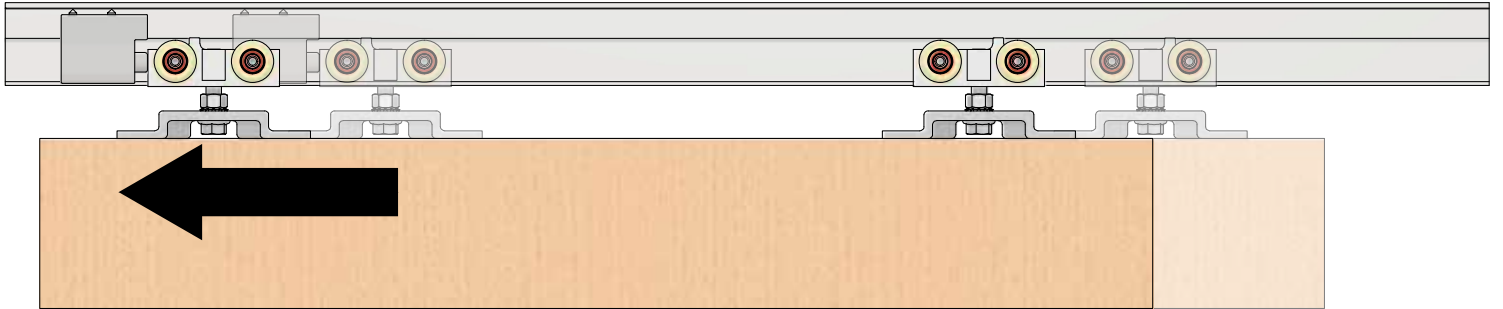

Step #12:

Once final position is achieved, slide door away from CC-101HD Stop. Lock CC-101HD Stop in position by tightening two cap screws on CC-101HD Stop with 3/16 in allen key. CC-101HD is secured by friction fit with cone point screws.



Step #13:

Repeat **steps #10 - 12** for opposite side.

Note: Ensure that strike and trim thickness are taken into consideration for final/desired position of door.

Step #14:

Before installing Catch 'N' Close Closing Devices, ensure devices are in retracted position as shown below. If not in required position, slide hook down until it locks in position.

Note: Requires significant finger pressure.

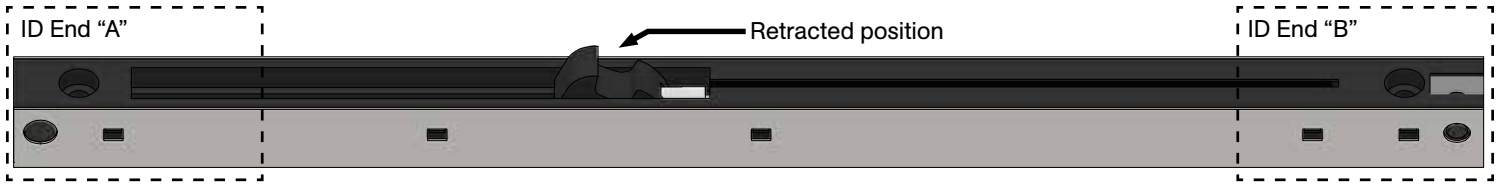

Important Catch 'N' Close Closing Device Notes:

If doors are 200 lbs. [90 kg] or less, ensure CC-2 Catch 'N' Close Closing Devices are used.

If doors are minimum 200 lbs. [90 kg] up to 300 lbs. [136 kg], ensure CC-3 Catch 'N' Close Closing Devices are used.

Step #15:

Place Catch 'N' Close Closing Device into track with leading end "A" resting against upper body on CC-101HD Stops installed previously. See illustrations below:

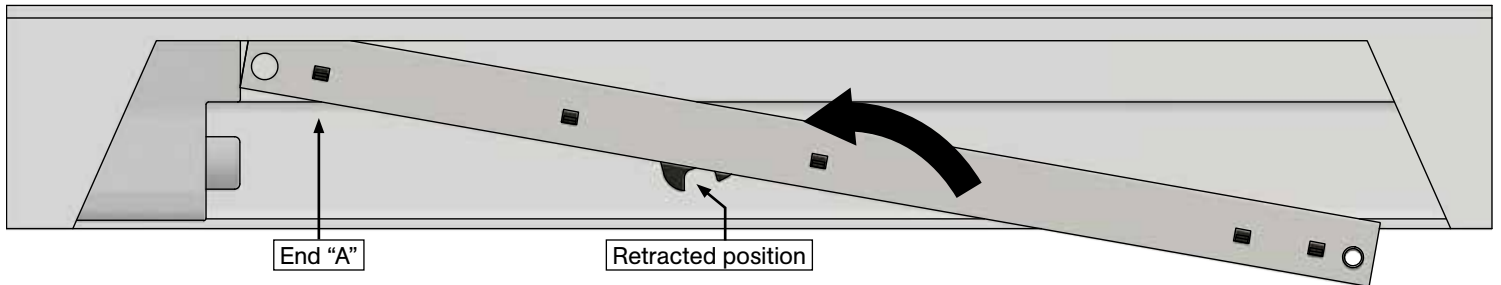

Step #16:

Secure Catch 'N' Close Closing Device to track with (2) #10 x 1-1/2" Self-Drilling Screws [FT5]. Repeat for opposite end with Catch 'N' Close Closing Device installed in reverse as shown on front page in "Elevation View" illustration.

Note: If using impact driver to secure Catch 'N' Close Devices, do not overtighten screws. It is recommended to pre-drill track with Ø9/64 in [3.6 mm] drill bit. Secure first screw closest to CC-101HD Stop only and test system by sliding door to activate Catch 'N' Close. If in correct position, secure with second screw. Remove any drill fillings from inside track.

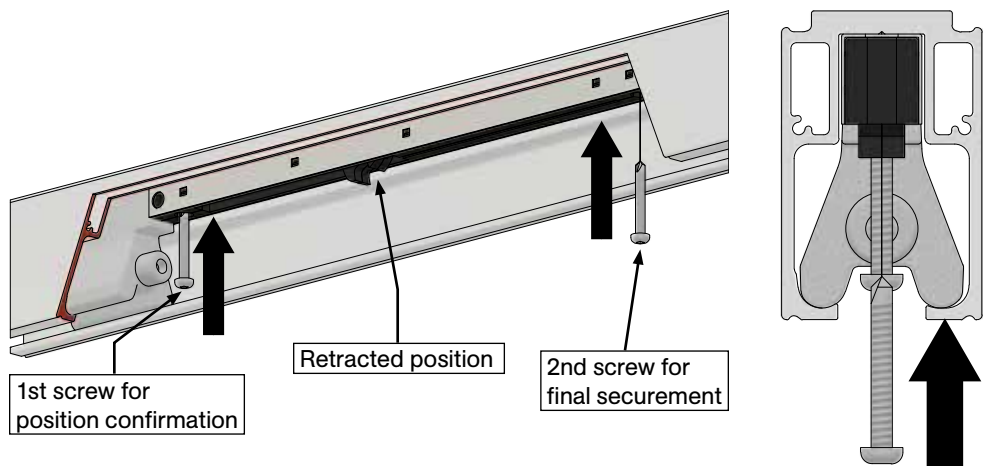

Note: Ensure area of track where Catch 'N' Close Device will be installed is free of fasteners. Securing Catch 'N' Close Device on top of a fastener may lead to operation issues or damage to the system.

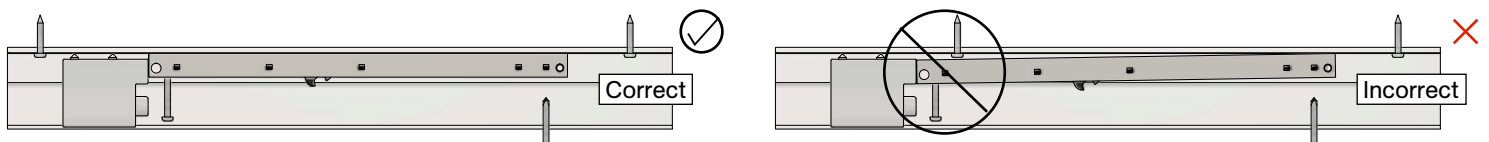

Step #17:

Test complete Catch 'N' Close system by sliding door to both left and right to activate closing devices.

Optional CC-940 Fascia and CC-941/CC-942/CC-943 End Cap Installation

Step #F1:

Cut CC-940 Fascia to correct length if required. Typically, fascia is same length as track previously installed.

Step #F2:

Lift fascia up to track and snap on as shown right.

Note: If fascia is loose and a tighter fit is desired, use a rubber mallet on inside leg of fascia to reduce gap at +/-24 in [610 mm] intervals.

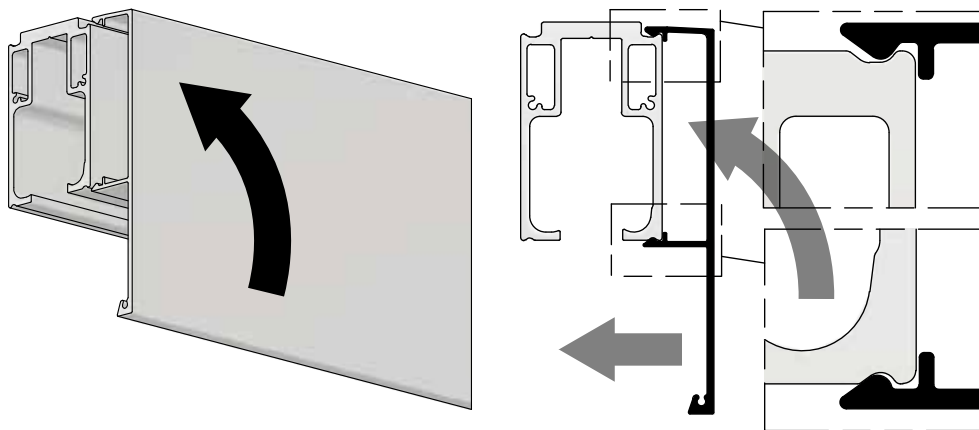

Step #F3:

Install end cap as shown below with the supplied #4 x 5/16" Flathead Screws [FT29], 2 - 4 screws per end cap provided.

Note: Do not install with impact driver.

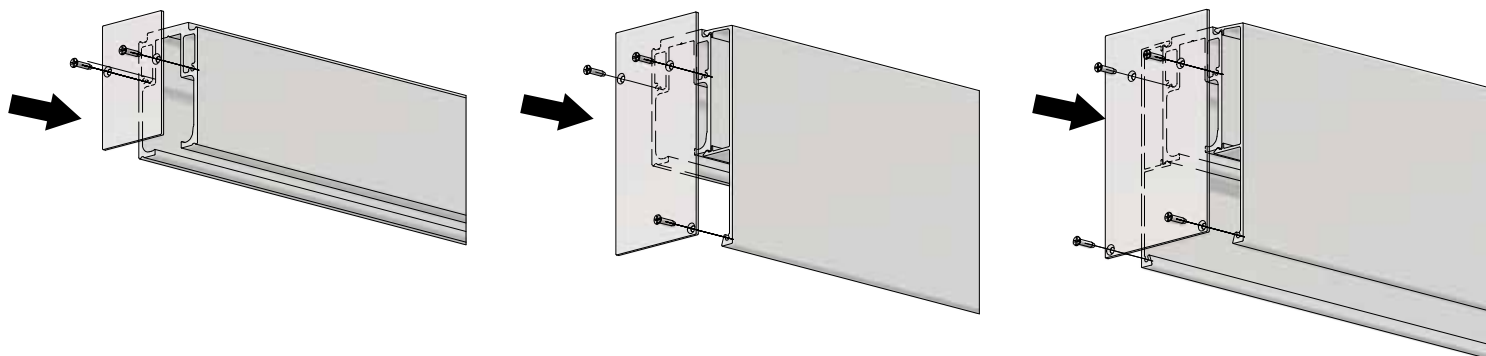

Troubleshooting

Issue	Solution
Chatter/noise when door is sliding	Ensure there are no aluminum shavings within track. Shavings can become embedded in nylon tires and cause noise during operation.
Door is hard to move	Ensure guide channel secured to bottom of door is not over-tightened as this could cause sides of guide channel to "pinch" guide. Remove door and check guide channel by rolling guide roller in channel to ensure smooth travel. There should be little to no resistance. Ensure door is not dragging on bottom of floor/guides and adjust height of door as required.
Door rattles	Ensure locking nuts and screws on hangers are secured and not loose.
Door is not engaging closing device	Ensure hangers are correctly oriented. See steps #4 - 5 . Ensure Catch 'N' Close Closing Devices are in correct retracted or extended position prior to sliding door closed/open. See step #14 .
Replacing the Catch 'N' Close Device	The Catch 'N' Close track and hardware system has been designed for easy installation. Remove two screws that hold Catch 'N' Close Closing Device in place and replace device with a new one if failure occurs.

Top Plate Location Template

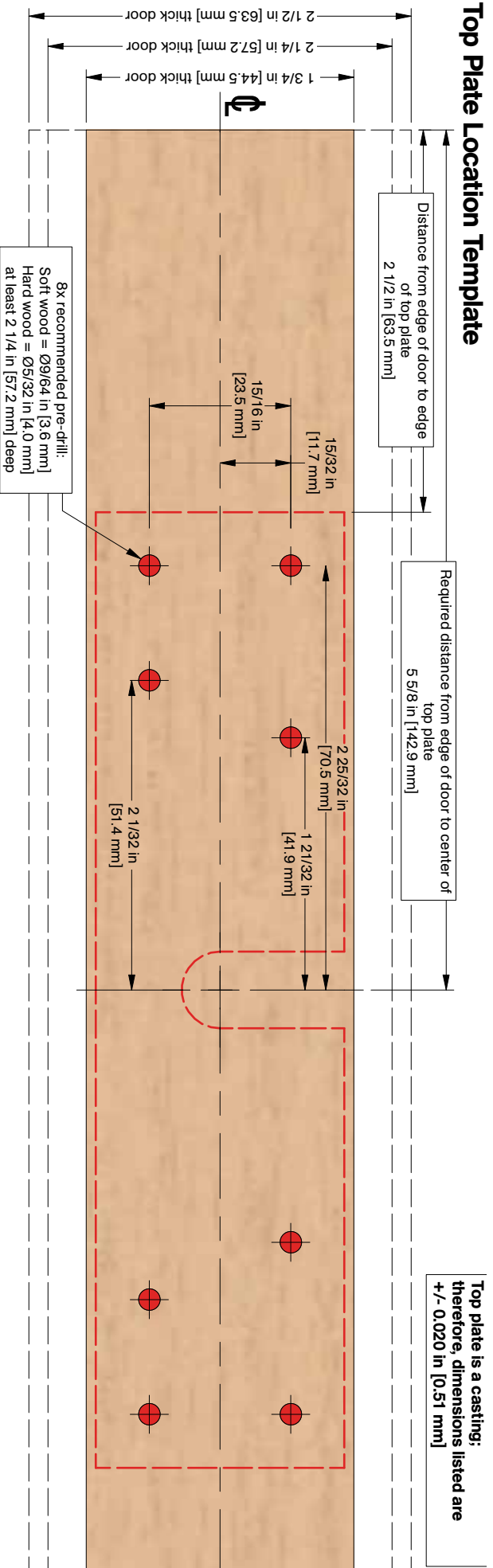

Top Plate Location Template

